

I made quite some progress:

- Had to cut screws since countersink will cause them to break. Probably difference from stepper to stepper.
- Gears A,B,C on your picture is shown screw but on latest version is a square hole. Not sure how did you imagine to lock the gears on stepper shaft

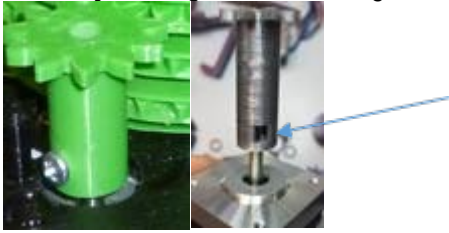

- Extruder :

On below picture the extruder gear have longer shaft but on last version the gears are thin and no shaft. I believe few parts are missing.

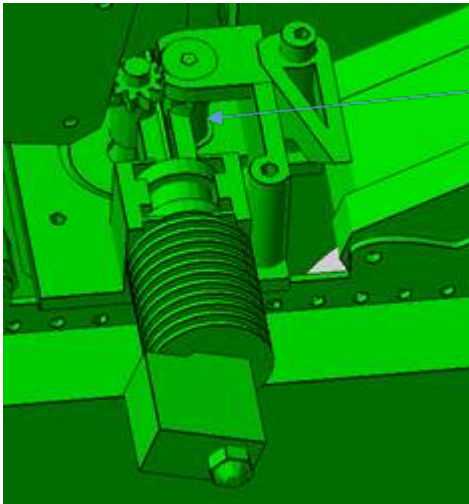

Parts in stl + shaft :



Here what I have succeeded :

