

Cost effective Type (Ct Grade) of LM Guide Debuts

A cost effective series of the well-established model HSR has been newly added.
Optimal for the general linear guide market such as for conveyance systems!

HSR (Ct Grade)



Integrating THK's unique processing technologies, we offer an LM Guide series for reasonable prices that meet the price demand in the market for general conveyance systems and the like.

Model HSR with Ct Grade

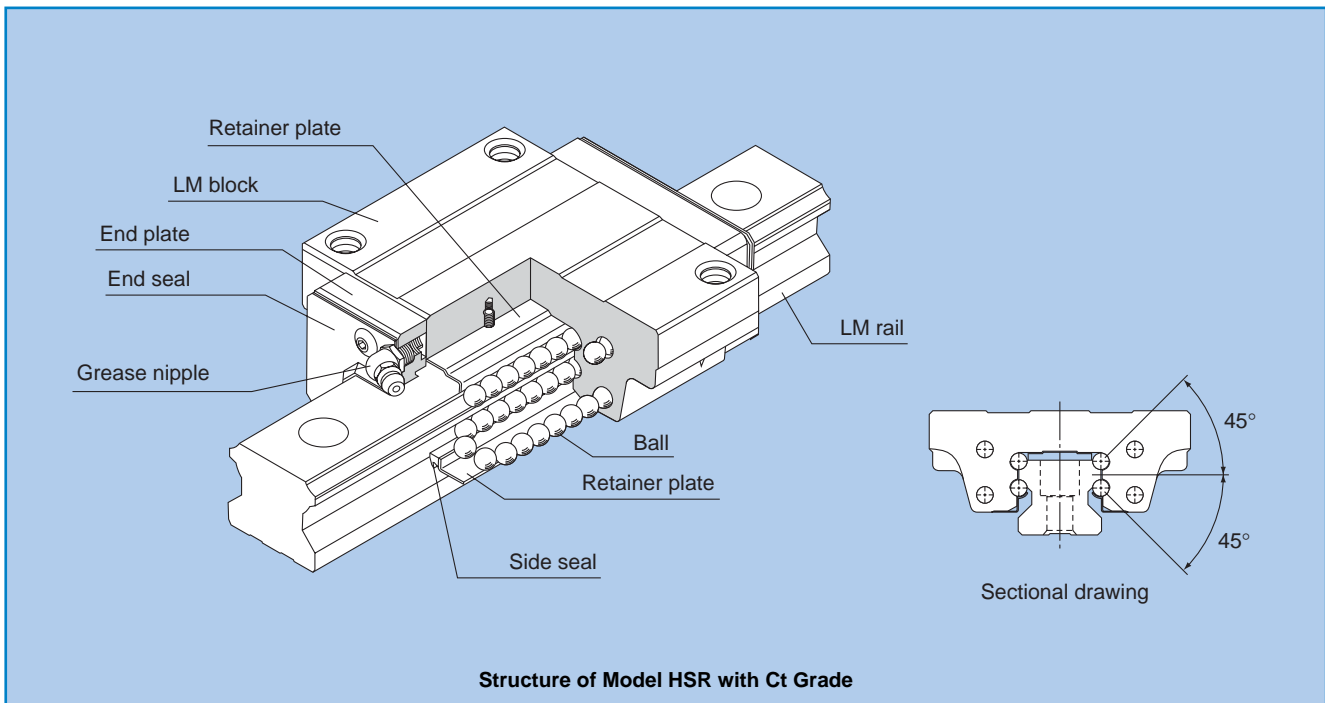

4-way equal-load type with global-standard size that allows for ease of design

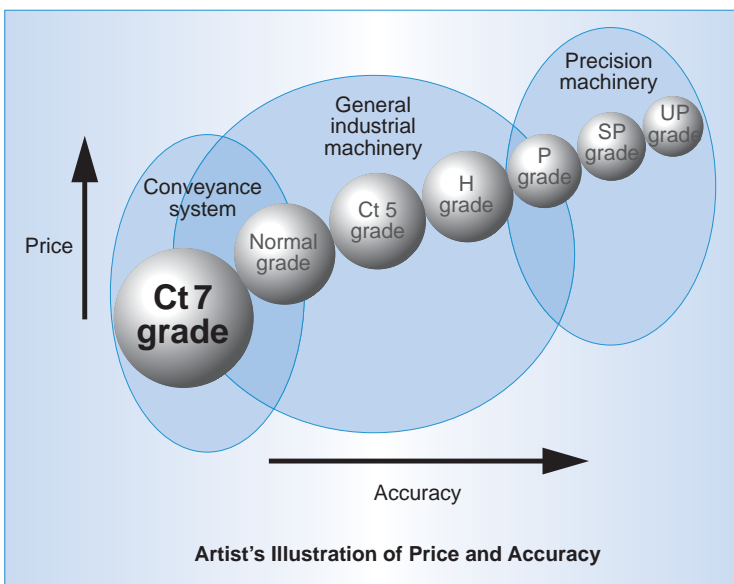

● Cost effective

- Sufficient performance is ensured despite the product being cost effective.
- Cost effectiveness contributes to cost cutting for the machine.

● Versatility

- 4-way equal-load type with global-standard size allows for ease of design.
- Suitable for general linear guides that do not require high accuracy such as general conveyance systems.
- Superb error-absorbing capability.

● Short delivery time

- Since LM rails and LM blocks are individually kept in stock, shorter delivery time than assembly-based products is achieved.
- Suitable for urgent delivery and repair of the LM block.

Model HSR-C with Ct Grade

The flange of the LM block has tapped holes.
Mountable from the top and the bottom.
Used when the table cannot have through holes for mounting bolts.

- HSR 15C ● HSR 30C
- HSR 20C ● HSR 35C
- HSR 25C

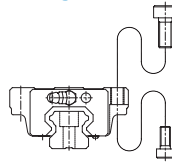
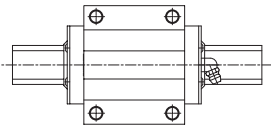

Model HSR-R with Ct Grade

Has a smaller LM block width (W), and tapped holes in the mounting section.
Optimal for locations with limited space on the table.

- HSR 15R ● HSR 30R
- HSR 20R ● HSR 35R
- HSR 25R

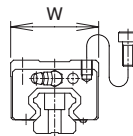
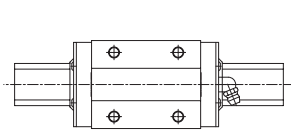

Accuracy Standard

The table below and the graph to the right show the accuracy standards such as for running parallelism and the dimensional tolerance in height and width of the LM Guide model HSR with Ct grade.

Unit: mm

Model number	Accuracy standard	Ct grade
	Item	Ct5, Ct7
15 20	Dimensional tolerance in height M	± 0.12
	Difference in height M	0.025
	Dimensional tolerance in width W ₂	± 0.12
	Difference in width W ₂	0.025
	Running parallelism of surface C against surface A	ΔC (as per figure)
	Running parallelism of surface D against surface B	ΔD (as per figure)
25 30 35	Dimensional tolerance in height M	± 0.12
	Difference in height M	0.025
	Dimensional tolerance in width W ₂	± 0.12
	Difference in width W ₂	0.035
	Running parallelism of surface C against surface A	ΔC (as per figure)
	Running parallelism of surface D against surface B	ΔD (as per figure)

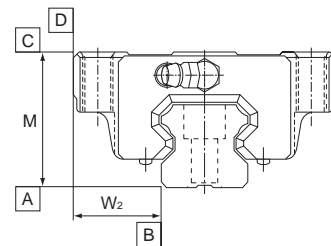

LM Rail Length and Running Parallelism

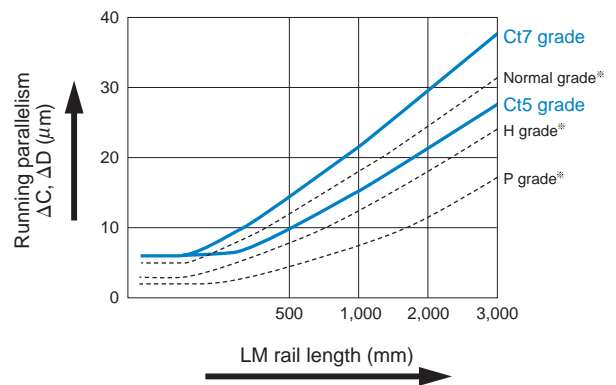

※ Accuracy standards for conventional types

Note: The difference in height M indicates the value when move "multiple" to the next line, do not break it blocks are assembled on one LM rail.

Radial Clearance

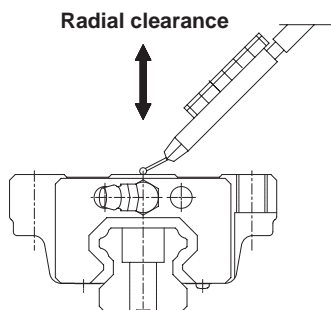

The table below shows the radial clearance of the LM Guide model HSR with Ct grade.

Unit: μm

Model number	Radial clearance
15	- 8 to +2
20	-14 to +2
25	-16 to +2
30	-18 to +4
35	-20 to +4

Service Life

Rated life

The rated life (L) means the total travel distance that 90% of a group of units of the same model can achieve without flaking (scale-like exfoliation on the metal surface) after individually running under the same conditions.

The rated life of model HSR with Ct grade is obtained from equation (1).

$$L = \left(\frac{f_H \cdot f_T \cdot f_C}{f_W} \cdot \frac{C}{P_C} \right)^3 \times 50 \dots\dots\dots(1)$$

Note: The basic load rating (C) indicates the load with constant direction and magnitude, under which the rated life (L) is L = 50 km, when a group of identical LM Guide units are independently operating under the same conditions.

- L: Rate life (km)
- C: Basic dynamic load rating (N)
- P_c: Calculated load (N)
- f_H: Hardness factor (see the General Catalog)
- f_T: Temperature factor (see the General Catalog)
- f_C: Contact factor (see the General Catalog)
- f_W: Load factor (see the General Catalog)

Service life time

Once the rated life (L) has been obtained, the service life time can be obtained using equation (2) if the stroke length and the number of reciprocations are constant.

$$L_h = \frac{L \times 10^6}{2 \times \ell_s \times n_1 \times 60} \dots\dots\dots(2)$$

- L_h: Service life time (h)
- ℓ_s: Stroke length (mm)
- n₁: No. of reciprocations per minute (min⁻¹)

OPTIONS

For model HSR with Ct grade, dust-prevention accessories are available. When desiring one, specify the corresponding symbol from the table below (for the dust prevention accessory symbols, see pages a-24 to a-25 in the General Catalog No. 401E).

For the supported model numbers and the overall LM block length (L dimension) with a dust prevention accessory attached, the respective values for model HSR apply. Bellows and the dedicated C-cap for LM rail mounting holes are also available.

For details of the options, see the General Catalog.

Dust Prevention

Dust Prevention Accessories for Model HSR with Ct Grade

Dust-prevention option	Effect/application
End seal	Attached on both ends of the LM block, it prevents foreign matter or water adhering to the top and side surfaces of the LM rail from entering the LM block. In addition, it is available as standard as a means to prevent the lubricant inside the LM block from leaking out.
Side seal	Used in locations where dust can enter the LM block from the side or bottom surface.

Symbol for Dust Prevention Accessories for Model HSR with Ct Grade

Symbol	Dust prevention accessory
SS	End seal + side seal (standard)

End seal

Used in locations with dust

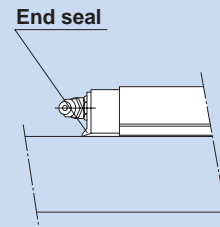

Side seal

Used in locations where dust can enter the LM block from the side or bottom surface such as vertical mount and inverted mount.

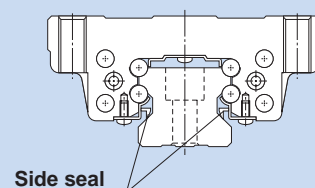

Dedicated C-cap for LM Rail Mounting Holes

If any of the LM rail mounting holes of an LM Guide is filled with cutting chips or foreign matter, they may enter the LM block. Entrance of such foreign matter can be prevented by covering each LM rail mounting hole with the dedicated cap so that the top of the mounting holes is on the same level as the LM rail top surface.

Since the dedicated C-cap for LM rail mounting holes uses a special synthetic resin with high oil resistance and high wear resistance, it is highly durable.

Major Dimensions of Dedicated C-cap

Model number	C-cap model number	Bolt used	Major dimensions (mm)	
			D	H
15	C4	M4	7.8	1.0
20	C5	M5	9.8	2.4
25	C6	M6	11.4	2.7
30	C8	M8	14.4	3.7
35	C8	M8	14.4	3.7

Dedicated C-cap for LM rail mounting holes

It prevents cutting chips from entering the LM rail mounting holes.

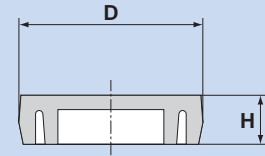

Standard Length and Maximum Length of the LM Rail

The table below shows the standard lengths and the maximum lengths of LM Guide model HSR variations with Ct grade. The longer the G dimension is, the less stable the G area after installation may become, thus adversely affecting the accuracy. Each model HSR product with Ct grade is shipped with its LM rail cut into the desired length. When placing an order, specify the overall LM rail length and the "G" and "g" dimensions. If the maximum length of the desired LM rail exceeds the corresponding value in the table, connected rails are used. In such a case, be sure to specify the overall length.



Standard Length and Maximum Length of the LM Rail for Model HSR with Ct Grade

Unit: mm

Model number	HSR15	HSR20	HSR25	HSR30	HSR35
Standard LM rail length (L ₀)	160	160	220	280	280
	220	220	280	360	360
	280	280	340	440	440
	340	340	400	520	520
	400	400	460	600	600
	460	460	520	680	680
	520	520	580	760	760
	640	580	640	840	840
	760	640	700	920	920
	820	700	760	1000	1000
	1000	820	820	1160	1080
	1240	1000	1000	1240	1160
	1600	1240	1240	1640	1240
		1600	1600	1880	1640
		1840	2520	2040	
		2080	3000	2520	
		3000	3000	3000	
Standard pitch F	60	60	60	80	80
G	20	20	20	20	20
Maximum length	3000	3000	3000	3000	3000

Dimensional Table for Model HSR-C with Ct Grade

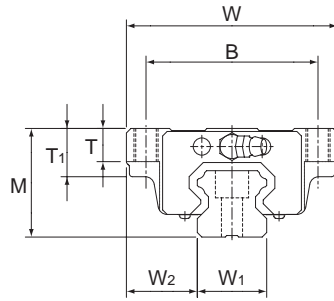

Model number	External dimensions			LM block dimensions										Grease nipple
	Height M	Width W	Length L	B	C	S	H	L ₁	T	T ₁	K	N	E	
HSR15C	24	47	56.6	38	30	M5	4.4	38.8	7	11	19.3	4.3	5.5	PB1021B
HSR20C	30	63	74	53	40	M6	5.4	50.8	10	9.5	26	5	12	B-M6F
HSR25C	36	70	83.1	57	45	M8	6.8	59.5	11	16	30.5	6	12	B-M6F
HSR30C	42	90	98	72	52	M10	8.5	70.4	9	18	35	7	12	B-M6F
HSR35C	48	100	109.4	82	62	M10	8.5	80.4	12	21	40.5	8	12	B-M6F

Dimensional Table for Model HSR-R with Ct Grade

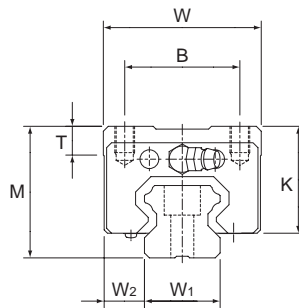

Model number	External dimensions			LM block dimensions									Grease nipple
	Height M	Width W	Length L	B	C	S	L ₁	T	K	N	E		
HSR15R	28	34	56.6	26	26	M4×5	38.8	6	23.3	8.3	5.5	PB1021B	
HSR20R	30	44	74	32	36	M5×6	50.8	8	26	5	12	B-M6F	
HSR25R	40	48	83.1	35	35	M6×8	59.5	9	34.5	10	12	B-M6F	
HSR30R	45	60	98	40	40	M8×10	70.4	9	38	10	12	B-M6F	
HSR35R	55	70	109.4	50	50	M8×12	80.4	11.7	47.5	15	12	B-M6F	

Model number coding

Block: **HSR25 C 1 SS Ct BLOCK**

1 2 3 4 5 6



Rail: **HSR25 - 3000L Ct7 RAIL**

7 8 9

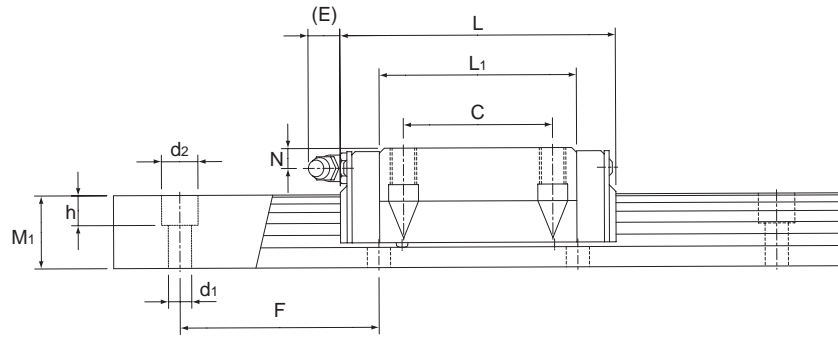
- 1 Model number
- 2 Type of LM block (C, R)
- 3 No. of blocks (1 in this example)
- 4 Dust prevention accessory symbol *1: (see page 3)
- 5 Indicates "Ct grade"
- 6 Block symbol
- 7 LM rail length (mm)
- 8 Indicates "Ct grade" (Ct5 grade, Ct7 grade)
- 9 Rail symbol



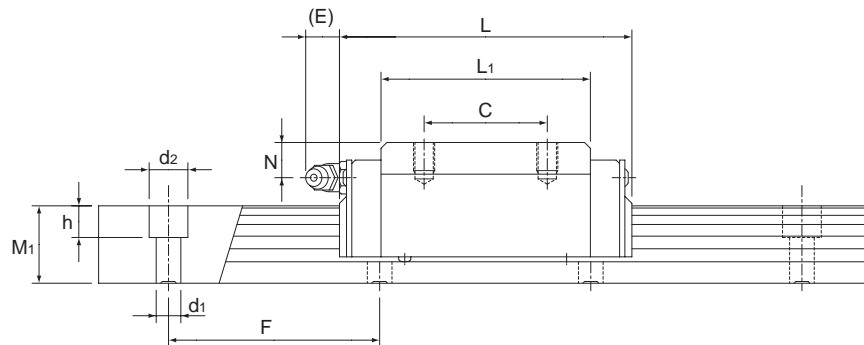

Unit: mm

	LM rail dimensions					Basic load rating		Permissible static moment kN-m ²			Mass	
	Width W ₁ _{-0.05} ⁰	W ₂	Height M ₁	Pitch F	d ₁ × d ₂ × h	C kN	C ₀ kN	M _A 	M _B 	M _C 	LM block kg	LM rail kg/m
	15	16	15	60	4.5 × 7.5 × 5.3	8.33	13.5	0.0805	0.0805	0.0844	0.2	1.5
	20	21.5	18	60	6 × 9.5 × 8.5	13.8	23.8	0.19	0.19	0.201	0.35	2.3
	23	23.5	22	60	7 × 11 × 9	19.9	34.4	0.307	0.307	0.344	0.59	3.3
	28	31	26	80	9 × 14 × 12	28	46.8	0.524	0.524	0.562	1.1	4.8
	34	33	29	80	9 × 14 × 12	37.3	61.1	0.782	0.782	0.905	1.6	6.6



Unit: mm

	LM rail dimensions					Basic load rating		Permissible static moment kN-m ²			Mass	
	Width W ₁ _{-0.05} ⁰	W ₂	Height M ₁	Pitch F	d ₁ × d ₂ × h	C kN	C ₀ kN	M _A 	M _B 	M _C 	LM block kg	LM rail kg/m
	15	9.5	15	60	4.5 × 7.5 × 5.3	8.33	13.5	0.0805	0.0805	0.0844	0.18	1.5
	20	12	18	60	6 × 9.5 × 8.5	13.8	23.8	0.19	0.19	0.201	0.25	2.3
	23	12.5	22	60	7 × 11 × 9	19.9	34.4	0.307	0.307	0.344	0.54	3.3
	28	16	26	80	9 × 14 × 12	28	46.8	0.524	0.524	0.562	0.9	4.8
	34	18	29	80	9 × 14 × 12	37.3	61.1	0.782	0.782	0.905	1.5	6.6



*1: For model HSR with Ct grade, "SS" is a standard combination.
*2: Indicates the permissible static moment with 1 LM block.

THK Model HSR with Ct Grade

Precautions on use

● Handling

- Disassembling components may cause dust to enter the system or degrade mounting accuracy of parts. Do not disassemble the product.
- Tilting an LM block or LM rail may cause them to fall by their own weight.
- Dropping or hitting the LM Guide may damage it. Giving an impact to the LM Guide could also cause damage to its function even if the guide looks intact.

● Lubrication

- Thoroughly remove anti-corrosion oil and feed lubricant before using the product.
- Do not mix lubricants of different physical properties.
- In locations exposed to constant vibrations or in special environments such as clean rooms, vacuum and low/high temperature, normal lubricants may not be used. Contact THK for details.
- When planning to use a special lubricant, contact THK before using it.
- When adopting oil lubrication, the lubricant may not be distributed throughout the LM system depending on the mounting orientation of the system. Contact THK for details.
- Lubrication interval varies according to the service conditions. Contact THK for details.

● Precautions on Use

- Entrance of foreign matter may cause damage to the ball circulating path or functional loss. Prevent foreign matter, such as dust or cutting chips, from entering the system.
- When planning to use the LM system in an environment where coolant penetrates the LM block, it may cause trouble to product functions depending on the type of coolant. Contact THK for details.
- Do not use the LM system at temperature of 80°C or higher. When desiring to use the system at temperature of 80°C or higher, contact THK in advance.
- If foreign matter adheres to the LM system, replenish the lubricant after cleaning the product. For available types of detergent, contact THK.
- When using the LM Guide with an inverted mount, breakage of the endplate due to an accident or the like may cause balls to fall out and the LM block to come off from the LM rail and fall. In these cases, take preventive measures such as adding a safety mechanism for preventing such falls.
- When using the LM system in locations exposed to constant vibrations or in special environments such as clean rooms, vacuum and low/high temperature, contact THK in advance.
- When removing the LM block from the LM rail and then replacing the block, an LM block mounting/removing jig that facilitates such installation is available. Contact THK for details.

● Storage

- When storing the LM Guide, enclose it in a package designated by THK and store it in a horizontal orientation while avoiding high temperature, low temperature and high humidity.

● “LM Guide,” “Ball Cage,” “,” and “QZ” are registered trademarks of THK CO., LTD.

- The photo may differ slightly in appearance from the actual product.
 - The appearance and specifications of the product are subject to change without notice. Contact THK before placing an order.
 - Although great care has been taken in the production of this catalog, THK will not take any responsibility for damage resulting from typographical errors or omissions.
 - For the export of our products or technologies and for the sale for exports, THK in principle complies with the foreign exchange law and the Foreign Exchange and Foreign Trade Control Law as well as other relevant laws.
- For export of THK products as single items, contact THK in advance.

All rights reserved