

NOTES:

1. MATERIAL: STAINLESS STEEL 316
2. FINISH: CLEAN
ALL DIMENSIONS APPLY AFTER FINISH.
3. MATERIAL AND FINISH MUST COMPLY WITH
CURRENT ROHS LEGISLATION.
4. BREAK ALL SHARPS.
5. USE AG55 TO CREATE CONE

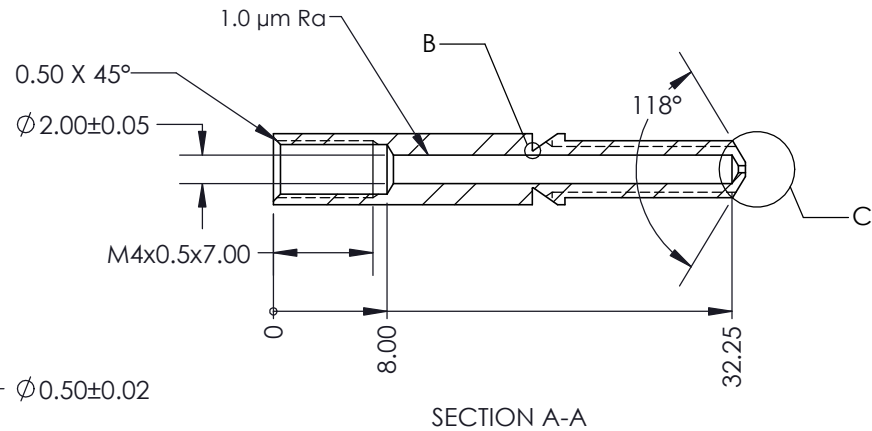
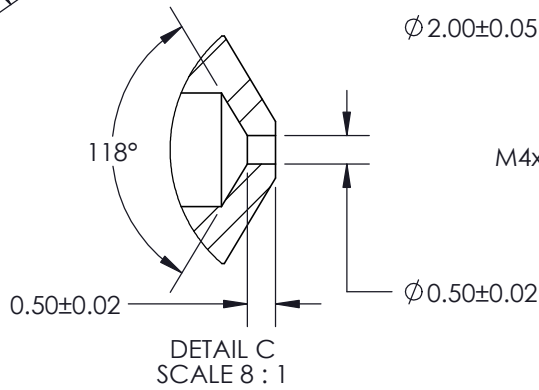
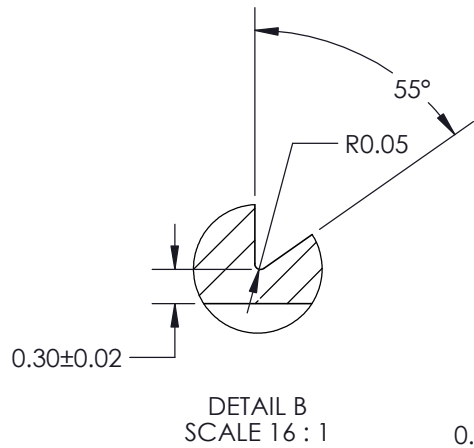
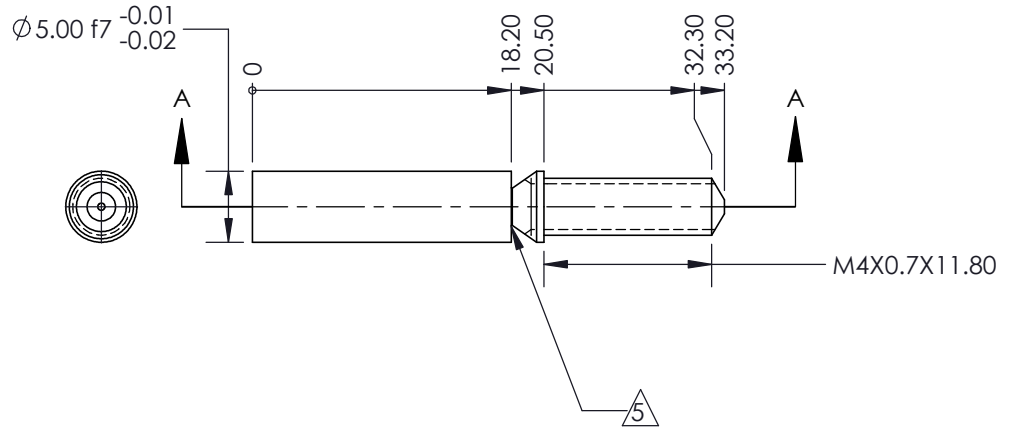

REVISIONS		
REV.	DESCRIPTION	DATE
1	INITIAL DRAWING	24/09/14
2	UPDATE ANGLE TO 118 DEGREES	29/09/14
00-000		27/11/2014

MASS: SEE NOTES	DIMENSIONS ARE IN MILLIMETERS	
MATERIAL: SEE NOTES	STD TOLERANCES: X±0.1 X.X±0.1 X.XX±0.10 ANGLES: ±0.5°	
FINISH: SEE NOTES	ENG.: R. JONES	24/09/14
 THIRD-ANGLE PROJECTION	DRAFT: R. JONES	29/09/14
	APPR: M GIACALONE	29/09/14

	PROJECT: RepRap Pro	
	DUAL HOT END	
0.5MM STAINLESS STEEL NOZZLE		
SIZE: A4	DWG NO.: 738	REV: 00-000
SCALE: 2:1		SHEET 1 OF 1